

CANDIDATE  
NAME

--

CENTRE  
NUMBER

--	--	--	--	--

CANDIDATE  
NUMBER

--	--	--	--

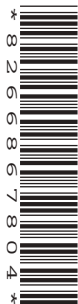

**MATHEMATICS**

**0580/21**

Paper 2 (Extended)

**October/November 2019**

**1 hour 30 minutes**

Candidates answer on the Question Paper.

Additional Materials:      Electronic calculator  
   Tracing paper (optional)

Geometrical instruments

**READ THESE INSTRUCTIONS FIRST**

Write your centre number, candidate number and name on all the work you hand in.

Write in dark blue or black pen.

You may use an HB pencil for any diagrams or graphs.

Do not use staples, paper clips, glue or correction fluid.

**DO NOT WRITE IN ANY BARCODES.**

Answer **all** questions.

If working is needed for any question it must be shown below that question.

Electronic calculators should be used.

If the degree of accuracy is not specified in the question, and if the answer is not exact, give the answer to three significant figures. Give answers in degrees to one decimal place.

For  $\pi$ , use either your calculator value or 3.142.

At the end of the examination, fasten all your work securely together.

The number of marks is given in brackets [ ] at the end of each question or part question.

The total of the marks for this paper is 70.

This document consists of **11** printed pages and **1** blank page.

- 1 Work out 5% of \$25.

\$ ..... [1]

- 2 Factorise  $5p + pt$ .

..... [1]

- 3 Calculate.

$$\frac{16.379 - 0.879}{4.2} \times 1.241$$

Give your answer correct to 2 significant figures.

..... [2]

- 4 Write 15 060

- (a) in words,

..... [1]

- (b) in standard form.

..... [1]

- 5 Simplify  $5c - d - 3d - 2c$ .

..... [2]

- 6 Solve.

$$\frac{x-2}{3} = 3$$

$x =$  ..... [2]

7 Simplify  $2x^3 \times 3x^2$ .

..... [2]

8 Without using a calculator, work out  $\frac{5}{16} \times 1\frac{1}{7}$ .

You must show all your working and give your answer as a fraction in its simplest form.

..... [2]

9 Paula invests \$600 at a rate of  $r\%$  per year simple interest.  
At the end of 10 years, the total interest earned is \$90.

Find the value of  $r$ .

$r =$  ..... [2]

10 Simplify.

$$\left(\frac{x^3}{8}\right)^{-\frac{4}{3}}$$

..... [2]

11  $P = 2r + \pi r$

Rearrange the formula to write  $r$  in terms of  $P$  and  $\pi$ .

$r = \dots\dots\dots$  [2]

12 The sides of a square are 15.1 cm, correct to 1 decimal place.

Find the upper bound of the area of the square.

$\dots\dots\dots \text{cm}^2$  [2]

13

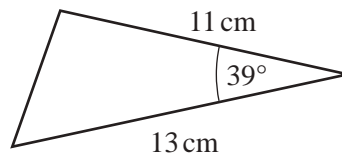

NOT TO  
SCALE

Calculate the area of the triangle.

$\dots\dots\dots \text{cm}^2$  [2]

- 14 The scale of a map is 1 : 10 000 000.  
On the map, the area of Slovakia is  $4.9 \text{ cm}^2$ .

Calculate the actual area of Slovakia.  
Give your answer in square kilometres.

.....  $\text{km}^2$  [3]

- 15  $y$  is inversely proportional to  $x^2$ .  
When  $x = 4$ ,  $y = 2$ .

Find  $y$  when  $x = \frac{1}{2}$ .

$y =$  ..... [3]

16

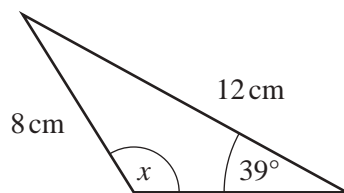

NOT TO  
SCALE

Calculate the **obtuse** angle  $x$  in this triangle.

$x =$  ..... [3]

17

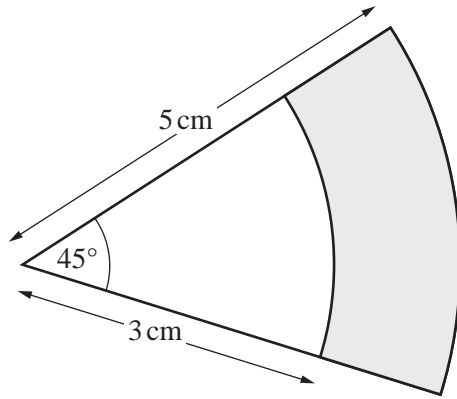
NOT TO  
SCALE

The diagram shows two sectors of circles with the same centre.

Calculate the shaded area.

..... cm<sup>2</sup> [3]

18 Write  $\frac{x}{2} - \frac{2x+4}{x+1}$  as a single fraction, in its simplest form.

..... [3]

$$19 \quad \mathbf{M} = \begin{pmatrix} 1 & 2 \\ 3 & 4 \end{pmatrix} \quad \mathbf{P} = \begin{pmatrix} 5 & 6 \\ 7 & 8 \end{pmatrix}$$

(a) Find  $\mathbf{MP}$ .

$$\begin{pmatrix} & \\ & \end{pmatrix} \quad [2]$$

(b) Find  $|\mathbf{M}|$ .

..... [1]

20 The probability that the school bus is late is  $\frac{9}{10}$ .

If the school bus is late, the probability that Seb travels on the bus is  $\frac{15}{16}$ .

If the school bus is on time, the probability that Seb travels on the bus is  $\frac{3}{4}$ .

Find the probability that Seb travels on the bus.

..... [3]

21

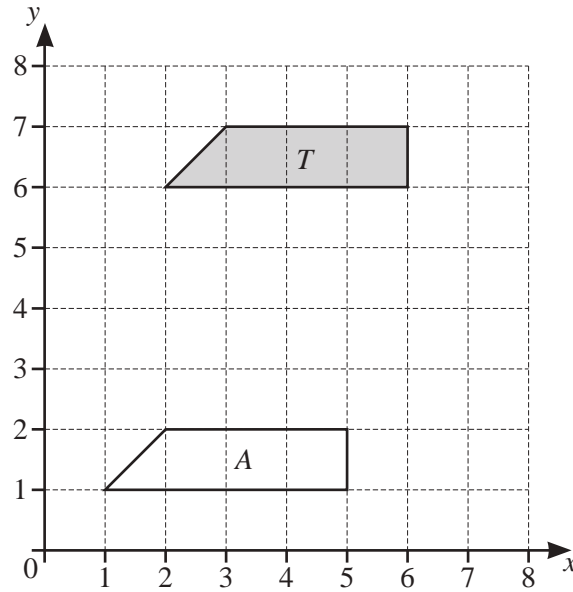

(a) Describe fully the **single** transformation that maps shape *T* onto shape *A*.

.....  
 .....

[2]

(b) On the grid, reflect shape *T* in the line  $y = x$ .

[2]

22 A pipe is completely full of water.  
 Water flows through the pipe at a speed of 1.2 m/s into a tank.  
 The cross-section of the pipe has an area of  $6 \text{ cm}^2$ .

Calculate the number of litres of water flowing into the tank in 1 hour.

..... litres [4]



23  $\mathcal{C} = \{0, 1, 2, 3, 4, 5, 6\}$

$A = \{0, 2, 4, 5, 6\}$

$B = \{1, 2, 5\}$

Complete each of the following statements.

$$A \cap B = \{\dots\dots\dots\}$$

$$n(B) = \dots\dots\dots$$

$$\{0, 4, 6\} = \dots\dots\dots \cap \dots\dots\dots$$

$$\{2, 4\} \dots\dots\dots A$$

[4]

24  $f(x) = 3x - 5$

$g(x) = 2^x$

(a) Find  $fg(3)$ .

..... [2]

(b) Find  $f^{-1}(x)$ .

$f^{-1}(x) = \dots\dots\dots$  [2]

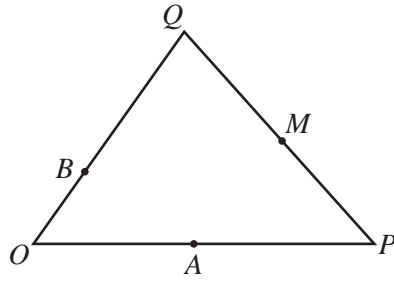

NOT TO SCALE

$O$  is the origin,  $\vec{OP} = 2\vec{OA}$ ,  $\vec{OQ} = 3\vec{OB}$  and  $\vec{PM} = \vec{MQ}$ .

$\vec{OP} = \mathbf{p}$  and  $\vec{OQ} = \mathbf{q}$ .

Find, in terms of  $\mathbf{p}$  and  $\mathbf{q}$ , in its simplest form

(a)  $\vec{BA}$ ,

$\vec{BA} = \dots\dots\dots$  [2]

(b) the position vector of  $M$ .

$\dots\dots\dots$  [2]

26

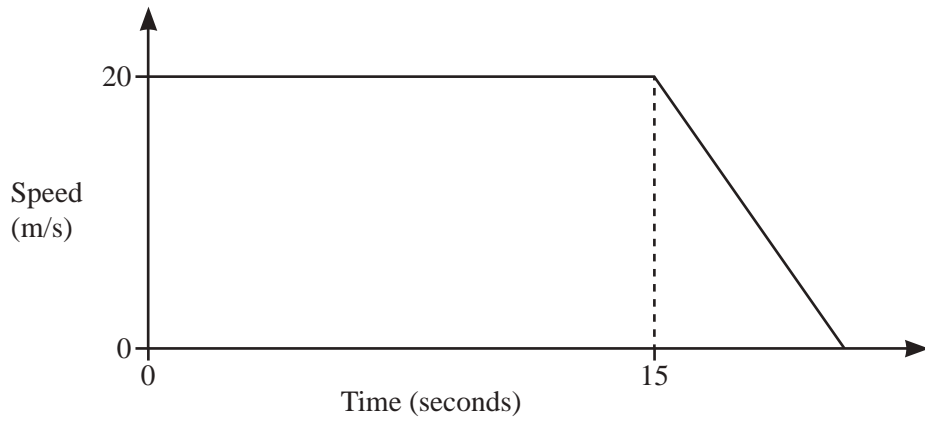

NOT TO SCALE

A car travels at 20 m/s for 15 seconds before it comes to rest by decelerating at  $2.5 \text{ m/s}^2$ .

Find the total distance travelled.

..... m [5]

**BLANK PAGE**

---

Permission to reproduce items where third-party owned material protected by copyright is included has been sought and cleared where possible. Every reasonable effort has been made by the publisher (UCLES) to trace copyright holders, but if any items requiring clearance have unwittingly been included, the publisher will be pleased to make amends at the earliest possible opportunity.

To avoid the issue of disclosure of answer-related information to candidates, all copyright acknowledgements are reproduced online in the Cambridge Assessment International Education Copyright Acknowledgements Booklet. This is produced for each series of examinations and is freely available to download at [www.cambridgeinternational.org](http://www.cambridgeinternational.org) after the live examination series.

Cambridge Assessment International Education is part of the Cambridge Assessment Group. Cambridge Assessment is the brand name of the University of Cambridge Local Examinations Syndicate (UCLES), which itself is a department of the University of Cambridge.